

# RIGHT-OF-WAY WIDTH: 110 FEET (HALF SECTION SHOWN)

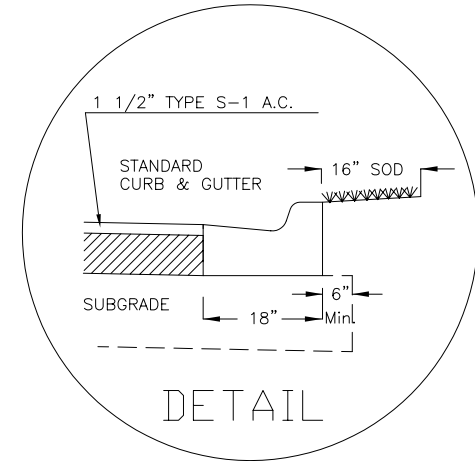
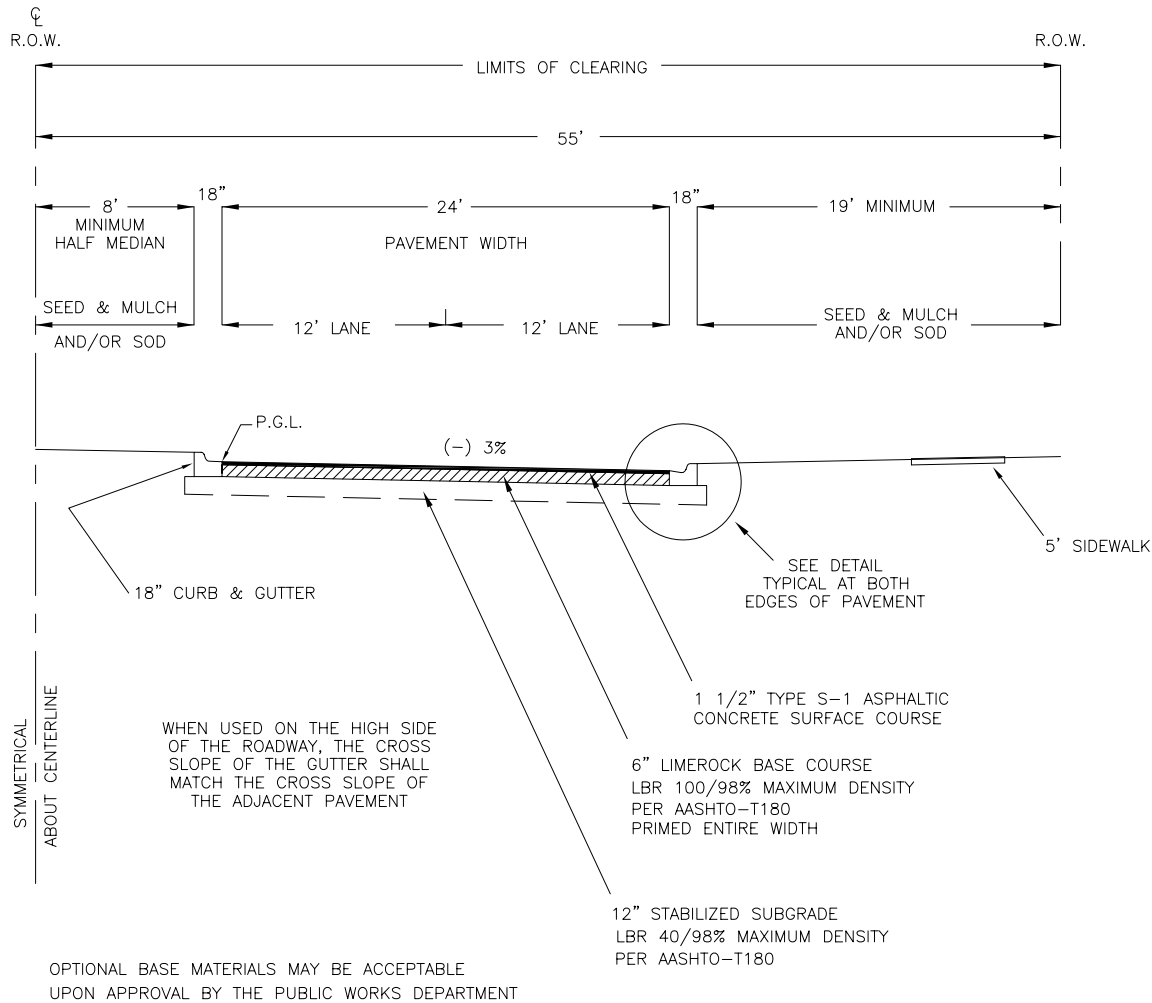

STRUCTURAL NUMBER: 2.70

ROADWAY AND DRAINAGE STANDARDS PUBLIC WORKS DEPARTMENT ENGINEERING DIVISION ST JOHNS COUNTY	REVISION DATES		MINOR COLLECTOR - 4 LANE TYPICAL CURB & GUTTER SECTION	DETAIL NO. 108A
	10/02			DWG: D108A____.DWG
				ADOPTED: