

REVISIONS	ST. JOHNS COUNTY UTILITY DEPARTMENT	TYPICAL ABOVE GROUND UTILITY MARKERS INSTALLATION	PLATE: G-9
Date	1205 STATE ROAD 16 ST. AUGUSTINE, FLORIDA 32084 Phone (904) 209-2700 • Fax (904) 209-2802	SCALE: N.T.S.	
2020	REVISION 1		

REVISIONS	ST. JOHNS COUNTY UTILITY DEPARTMENT	AIR VALVE ASSEMBLY WITH MANHOLE	PLATE: G-10
Date	1205 STATE ROAD 16 ST. AUGUSTINE, FLORIDA 32084 Phone (904) 209-2700 • Fax (904) 209-2802	SCALE: N.T.S.	
2020	REVISION 1		

REVISIONS	ST. JOHNS COUNTY UTILITY DEPARTMENT	TYPE "A" PIPE CROSSING WITH FITTINGS	PLATE: G-11
Date	1205 STATE ROAD 16 ST. AUGUSTINE, FLORIDA 32084 Phone (904) 209-2700 • Fax (904) 209-2802	SCALE: N.T.S.	
2020	REVISION 1		

REVISIONS	ST. JOHNS COUNTY UTILITY DEPARTMENT	TYPE "A" PIPE CROSSING WITH DEFLECTION	PLATE: G-12
Date	1205 STATE ROAD 16 ST. AUGUSTINE, FLORIDA 32084 Phone (904) 209-2700 • Fax (904) 209-2802	SCALE: N.T.S.	
2020	REVISION 1		

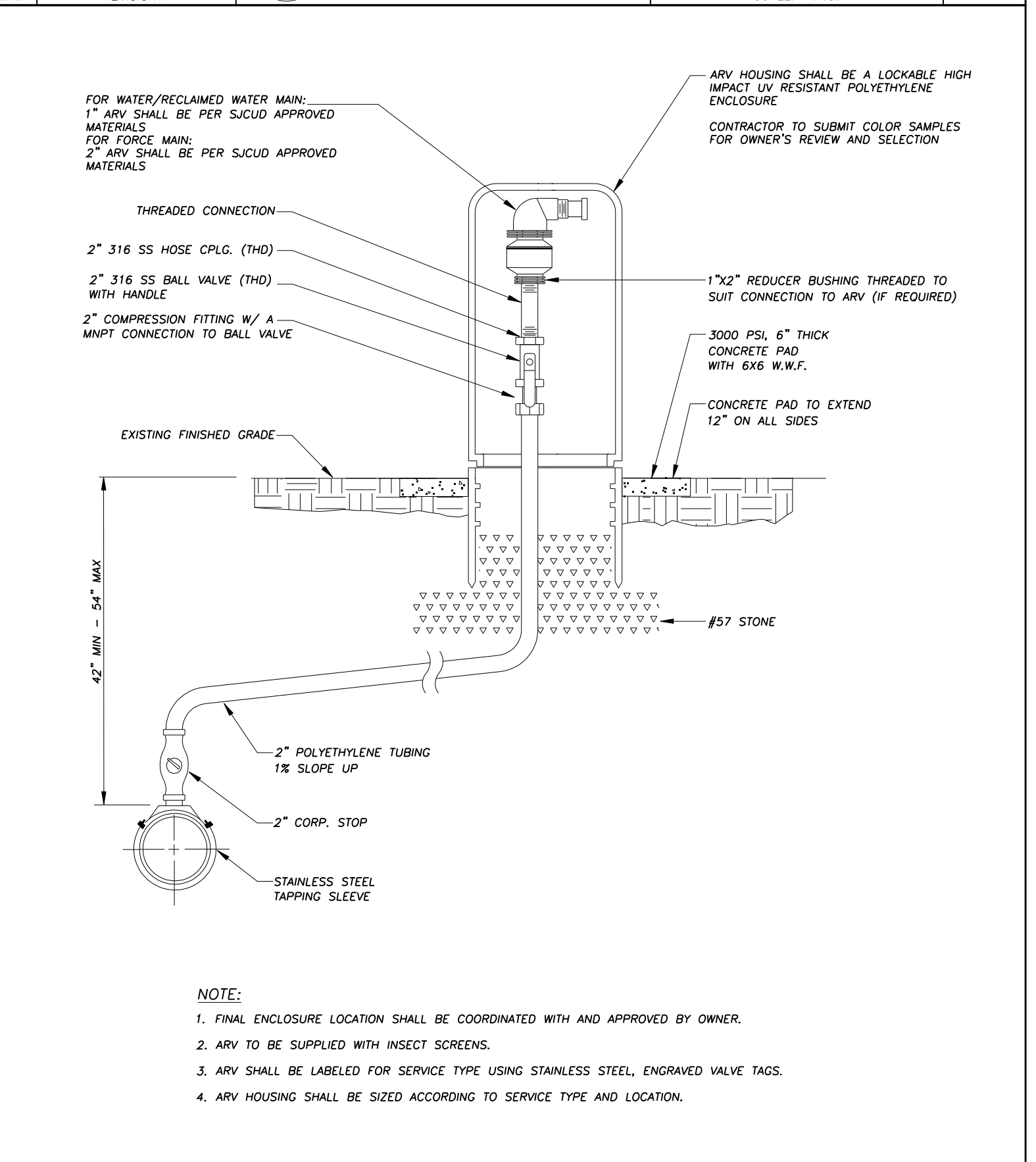
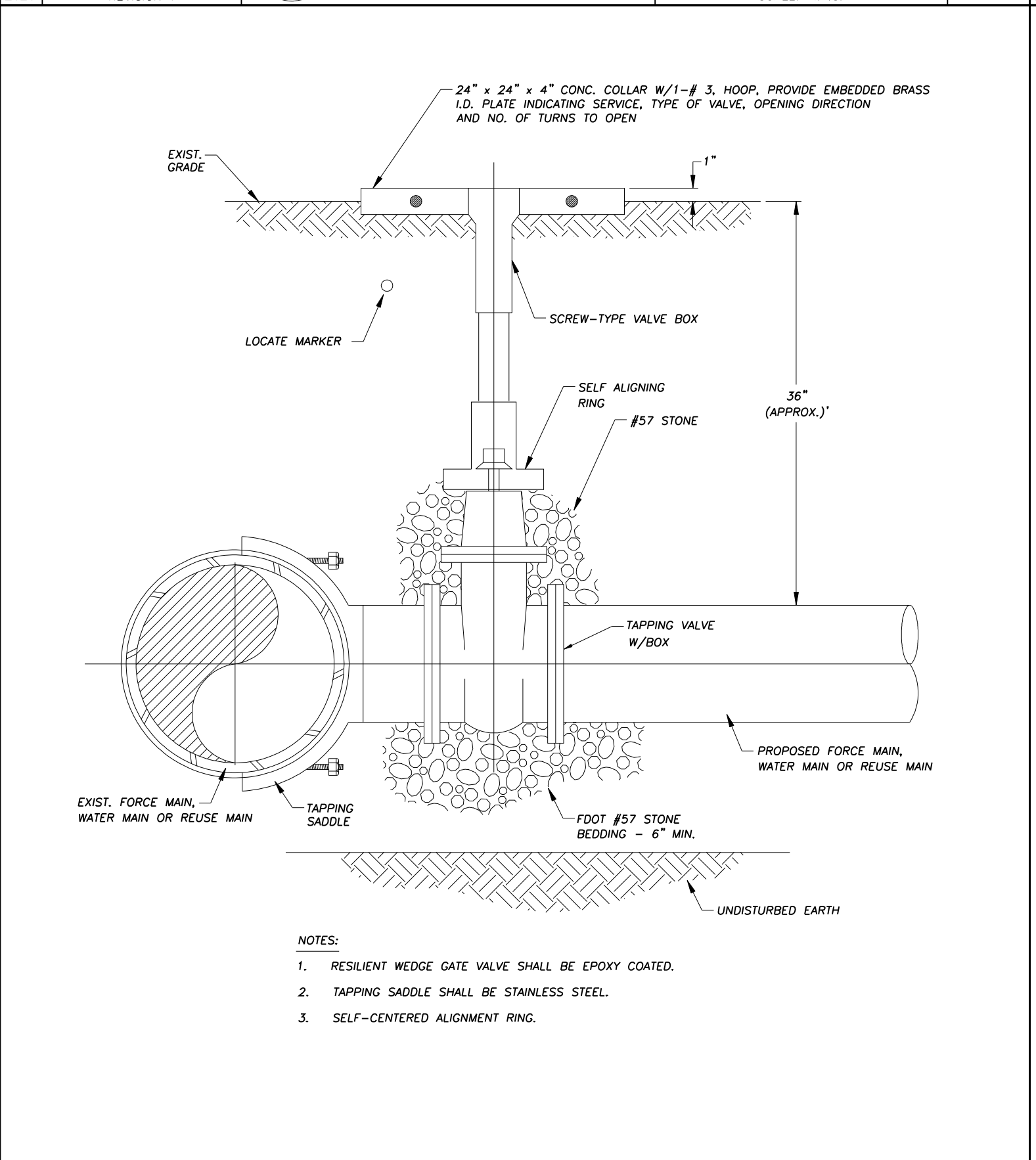
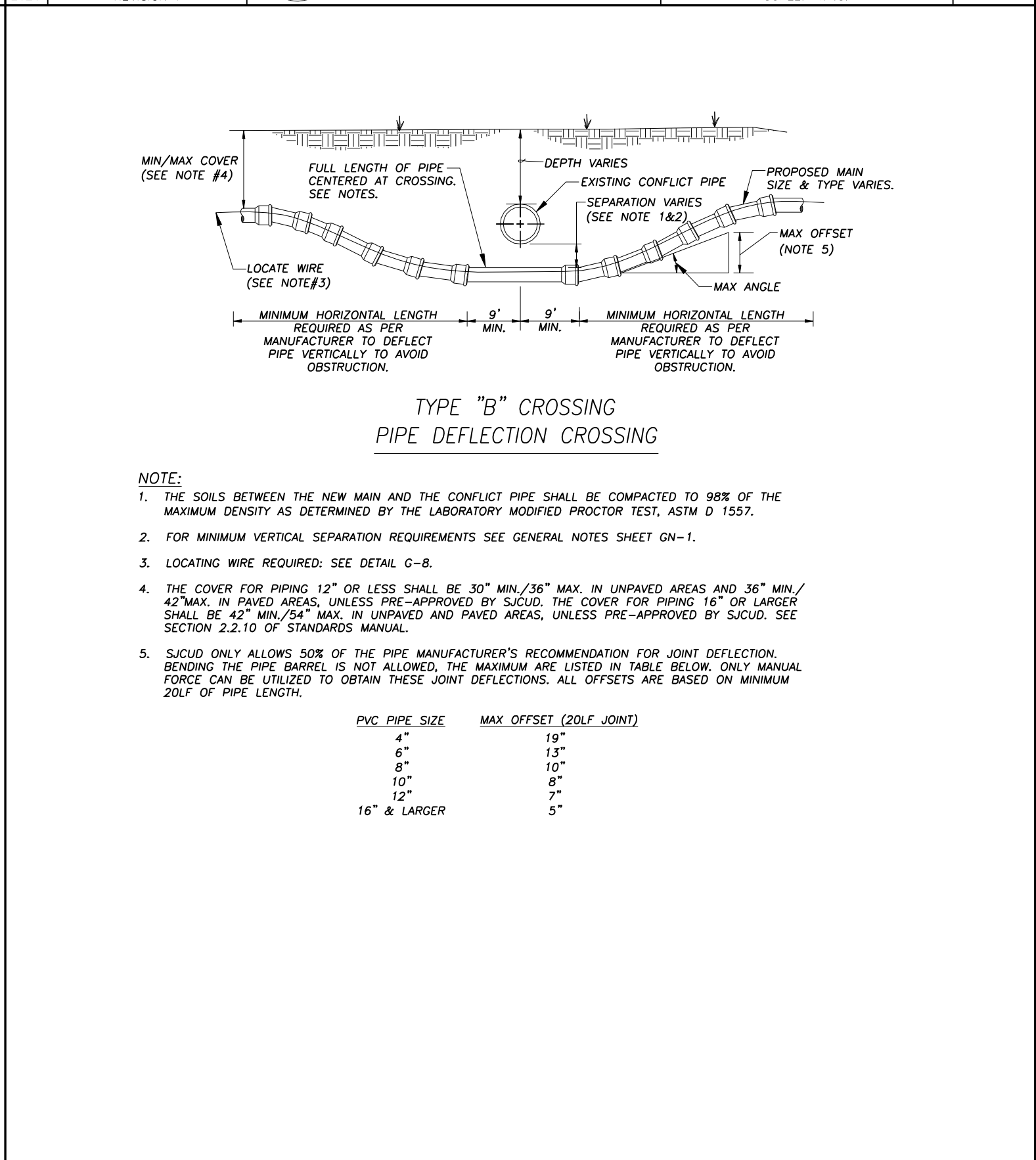
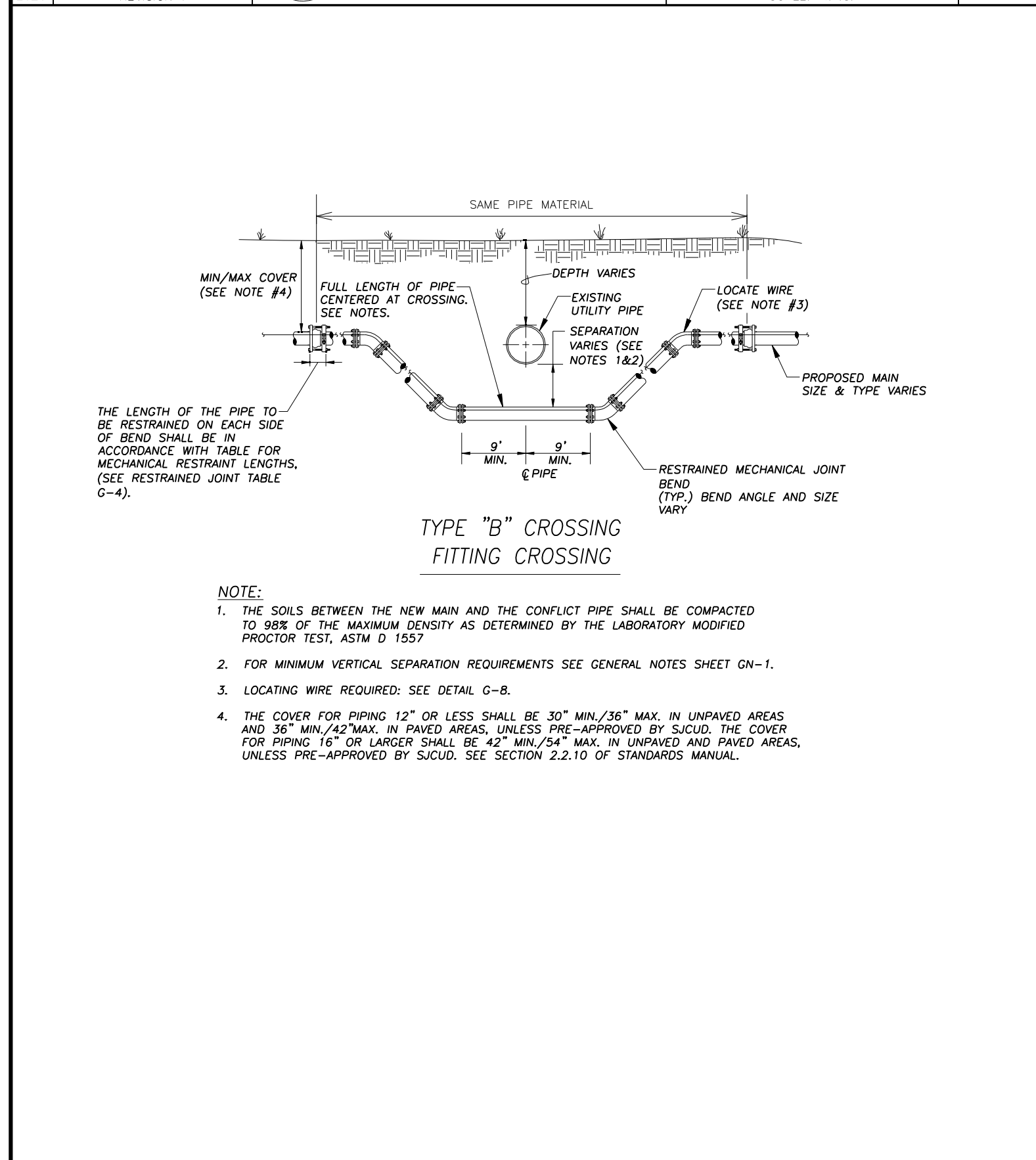

REVISIONS	ST. JOHNS COUNTY UTILITY DEPARTMENT	TYPE "B" PIPE CROSSING WITH FITTINGS	PLATE: G-13
Date	1205 STATE ROAD 16 ST. AUGUSTINE, FLORIDA 32084 Phone (904) 209-2700 • Fax (904) 209-2802	SCALE: N.T.S.	
2020	REVISION 1		

REVISIONS	ST. JOHNS COUNTY UTILITY DEPARTMENT	TYPE "B" PIPE CROSSING WITH DEFLECTION	PLATE: G-14
Date	1205 STATE ROAD 16 ST. AUGUSTINE, FLORIDA 32084 Phone (904) 209-2700 • Fax (904) 209-2802	SCALE: N.T.S.	
2020	REVISION 1		

REVISIONS	ST. JOHNS COUNTY UTILITY DEPARTMENT	TAPPING SADDLE & TAPPING VALVE DETAIL	PLATE: G-15
Date	1205 STATE ROAD 16 ST. AUGUSTINE, FLORIDA 32084 Phone (904) 209-2700 • Fax (904) 209-2802	SCALE: N.T.S.	
2020	REVISION 1		

REVISIONS	ST. JOHNS COUNTY UTILITY DEPARTMENT	ABOVE GROUND AIR RELEASE VALVE	PLATE: G-16
Date	1205 STATE ROAD 16 ST. AUGUSTINE, FLORIDA 32084 Phone (904) 209-2700 • Fax (904) 209-2802	SCALE: N.T.S.	
2020	REVISION 1		

NO.	BY	DATE	SYMBOL	REVISIONS
1.	SJCD	2020		REVISION 1

DESIGNER:	DESIGN ENGINEER
DRAWN BY:	
DATE:	
CHECKED BY:	FLORIDA REGISTRATION NO.
DATE:	

**ST. JOHNS COUNTY UTILITY DEPARTMENT**  
 1205 STATE ROAD 16  
 ST. AUGUSTINE, FLORIDA 32084-8646  
 Phone (904) 209-2700 • Fax (904) 209-2702

**GENERAL DETAILS**

NO. SHEETS
SHEET NO. D-2
DRAWING NO. D-02.dwg