

RIGHT-OF-WAY WIDTH: 60 FEET

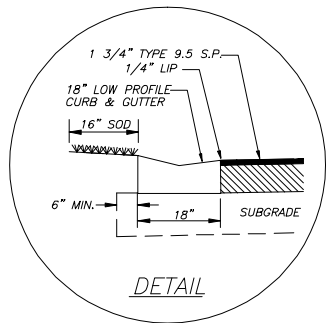
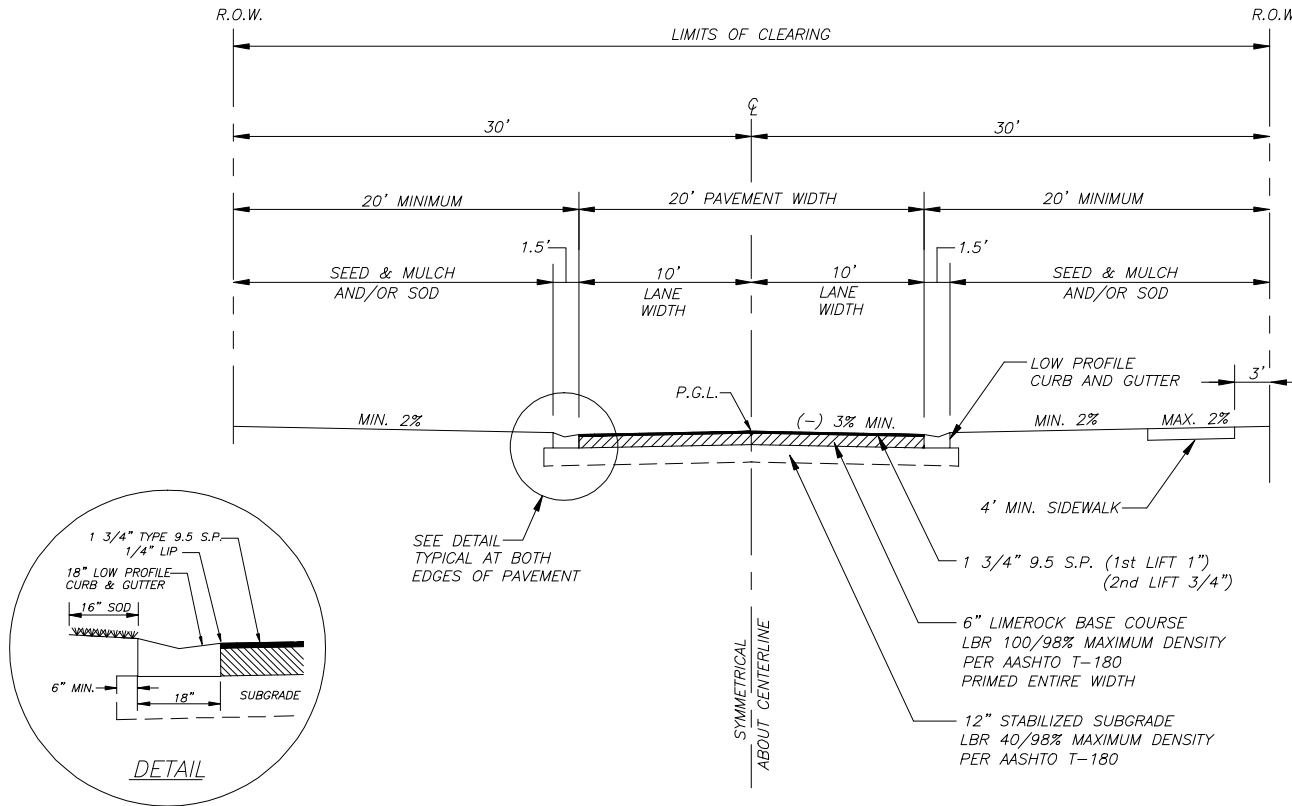

NOTES:

1. OPTIONAL BASE MATERIALS MAY BE ACCEPTABLE UPON APPROVAL BY THE COUNTY ENGINEER
2. 9.5 S.P. SHALL BE FINAL ASPHALT COURSE PLACED
3. GOLF CARTS MAY BE PERMITTED ON THIS ROADWAY TYPICAL SECTION WHEN PERMITTED THROUGH THE PROCESS IDENTIFIED IN ORDINANCE 2009-1 AND APPROVED BY THE COUNTY ENGINEER

TRAFFIC VOLUME < 1,500 AADT
RESIDENTIAL ROADS ONLY

STRUCTURAL NUMBER: 2.70



**ST JOHNS COUNTY
PUBLIC WORKS DEPARTMENT
ENGINEERING DIVISION**

2740 Industry Center Road
ST AUGUSTINE, FLORIDA 32084
Phone (904) 209-0110 • Fax. (904) 209-0140

REVISION
10/09

DESIGN DETAIL

**LOCAL ROAD-2 LANE-60' R.O.W.
TYPICAL CURB & GUTTER SECTION**

EFFECTIVE DATE:

DETAIL NO.

102

APPROVED:

[Signature]
H.P. TOMPKINS, JR., P.E.
COUNTY ENGINEER