

RIGHT-OF-WAY WIDTH: 130 FEET (HALF SECTION SHOWN)

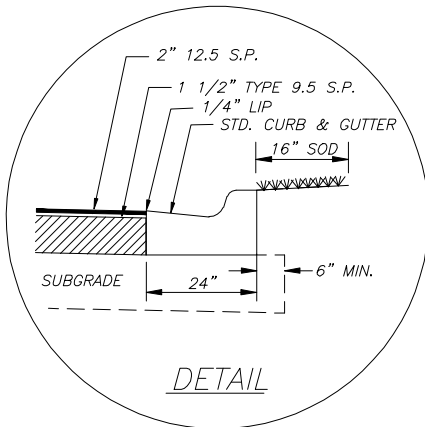
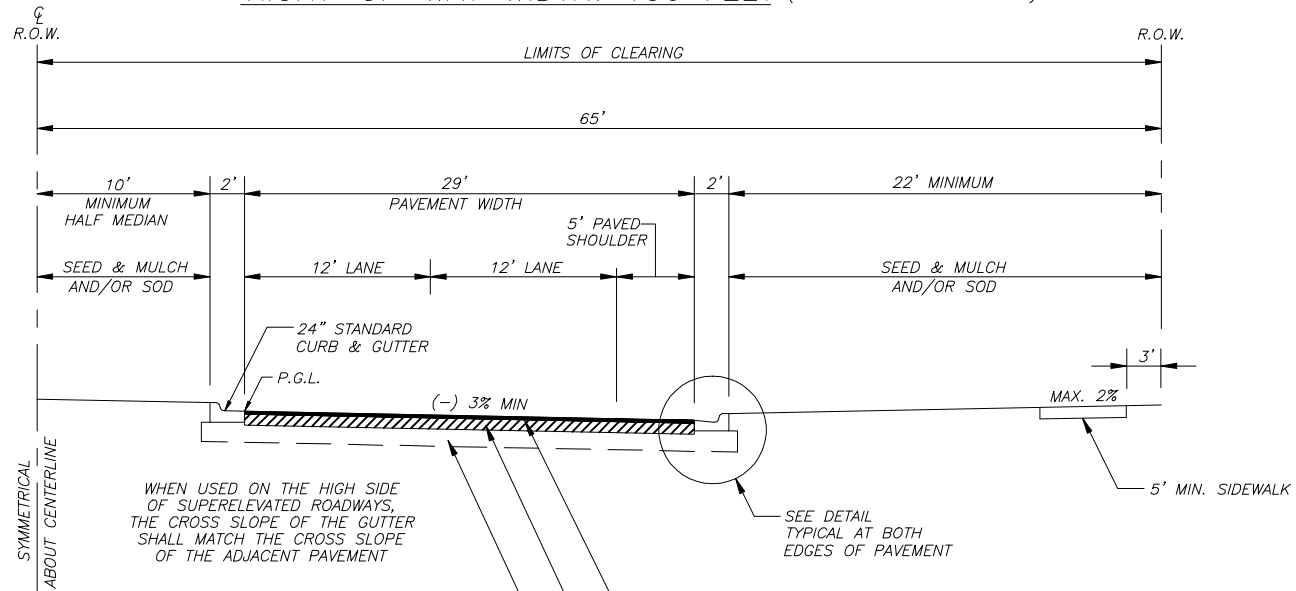

2" 12.5 S.P. OVERLAYED WITH 1 1/2" 9.5 S.P.  
 10" LIMEROCK BASE COURSE LBR 100/98% MAXIMUM DENSITY PER AASHTO T-180 PRIMED ENTIRE WIDTH  
 12" STABILIZED SUBGRADE LBR 40/98% MAXIMUM DENSITY PER AASHTO T-180

NOTES:

- OPTIONAL BASE MATERIALS MAY BE ACCEPTABLE UPON APPROVAL BY THE COUNTY ENGINEER
- 9.5 S.P. SHALL BE FINAL ASPHALT COURSE PLACED

TRAFFIC VOLUME  
11,000 < AADT < 28,000

STRUCTURAL NUMBER: 4.30



**ST JOHNS COUNTY**  
**PUBLIC WORKS DEPARTMENT**  
**ENGINEERING DIVISION**  
 2740 Industry Center Road  
 ST AUGUSTINE, FLORIDA 32084  
 Phone (904) 209-0110 • Fax. (904) 209-0140

REVISION
10/09

DESIGN DETAIL

MAJOR COLLECTOR-4 LANE-130' R.O.W.  
 TYPICAL CURB & GUTTER SECTION

EFFECTIVE DATE:  
 DETAIL NO. 109  
 APPROVED:  
  
 H.P. TOMPKINS, JR., P.E.  
 COUNTY ENGINEER