

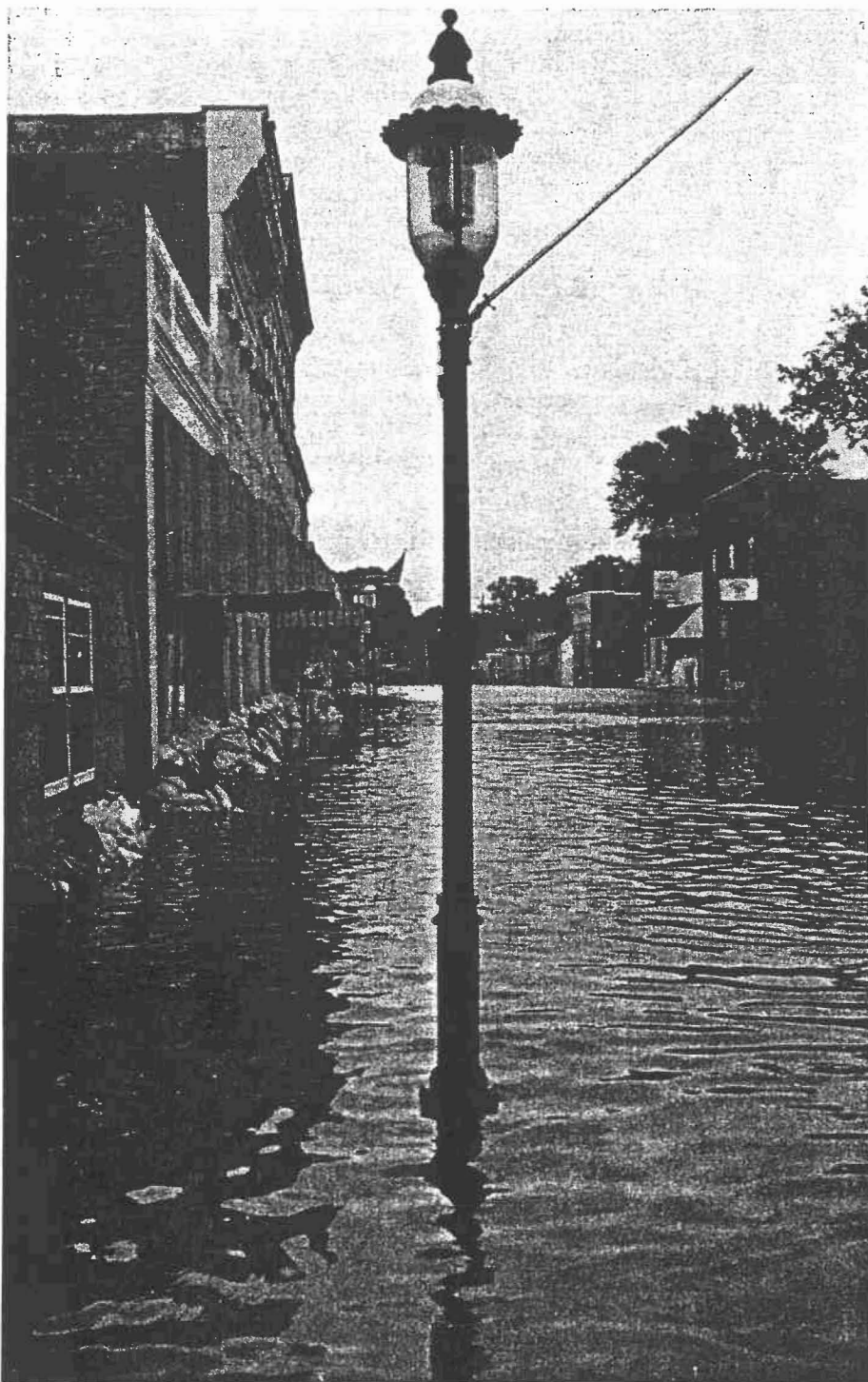

# INFORMATION

Information Booklet No. 82, 1993



*Credit: Leader-Record, photo by Steve Shriver*

## TREATMENT OF FLOOD-DAMAGED OLDER AND HISTORIC BUILDINGS

### *Inside:*

How to care for wet plaster

Problems with your  
foundation

Treatment for saturated  
wood-framed walls and floors

Exterior paint problems

Cleaning out the mud

How to treat historic  
wallpapers

Where to go for assistance

Checklist of practical  
considerations

*We encourage you to duplicate this material for distribution to anyone who might find it useful. It is our intent to get this information as quickly as possible to those individuals responsible for flood-damaged older and historic buildings.*

*Photo: Bonaparte, Iowa, July 1993*

**M**any older and historic buildings have been affected by the heavy rains and flooding that occurred during the spring and summer of 1993. The purpose of this booklet is to help building owners minimize structural and cosmetic flood damage. It contains general advice written to cover a wide variety of buildings with varying degrees of flood damage. If you suspect that your building may have some structural damage, contact a qualified structural engineer or architect to thoroughly assess the situation and suggest remedies. Your state historic preservation office (SHPO) can provide you with a list of architects who are experienced in the treatment of historic buildings.

A description of the tax credit programs for rehabilitation of historic structures, free technical publications available through your state historic preservation office and the Federal Emergency Management Agency (FEMA), telephone numbers you can call for more assistance, and additional resources are provided at the end of the booklet.

Once you are able to return to your building, the first tasks will likely be to remove mud and debris and to inspect the building for damage. Saving your building, no matter how historic, is not worth losing your life or risking permanent injury. Please observe these safety precautions:

- Do not walk through flowing water.
- Do not drive through a flooded area.
- Stay away from power lines and electrical wires.
- Make sure that all of your electricity is turned off. If any electrical wiring was submerged, have it inspected before turning the power back on.
- Look before you step. Floods deposit mud which makes most walking surfaces very slippery.

- Be alert for gas leaks.
- Carbon monoxide exhaust kills. If you use electrical generators or charcoal grills, make sure that they are properly vented.
- Clean everything that got wet. Floodwaters carry sewage and chemicals. Hose down concrete and masonry walls. Scrub all surfaces with disinfectant. Discard any food and medicine that came in contact with floodwater. Wear protective clothing and make sure the building is properly ventilated while working inside.
- Remember to follow local health guidelines concerning preventative shots or vaccinations.

### After the Water Recedes

No other "element" is as destructive to buildings as water. After your building has been saturated and once the floodwaters recede, it is important that the drying process begin immediately. Most of the damaging effects of water, such as rot, rust, and spalling, can be minimized by reducing both interior and exterior moisture levels.

The least damaging drying process appears to be one that begins by using only ventilation. To speed evaporation, interior air must be vented to the outside. The most effective way to do this is to open windows and doors and allow the moisture to escape. Fans can be used to speed evaporation by moving interior air and exhausting humid air to the outdoors.

Using heat or dehumidification too soon can damage your building. As materials begin to dry, small amounts of heat or dehumidification can be introduced. Use of mechanical means requires some caution:

- None of these devices should be used when water makes their operation dangerous.
- Ventilation remains the primary means of removing interior mois-

ture. All of these devices must be used in conjunction with a ventilation plan designed to exhaust moisture-laden air.

- Beware of using industrial drying equipment to remove moisture at a very fast rate. You are likely to cause permanent damage to wood and plaster.
- If heaters are used without ventilation, the relative humidity in the interior may actually increase and further spread moisture damage. If heaters are fuel powered, the lack of ventilation can be very dangerous to persons inside the building.

Enclosed portions of your building, such as wall cavities, may retain water for long periods of time which can pose a danger particularly to wooden elements such as wall studs, floor joists, and columns. It may be necessary to open walls and remove insulation. Later sections of this booklet contain specific recommendations.

Once the floodwaters recede, you will need to rinse remaining mud, dirt and flood debris from all surfaces with fresh water as soon as possible. It is safer and easier to remove the mud while it is still wet. Do not wait until the material is dry. Make sure that all electricity is turned off before cleaning with water. Avoid using high pressure water on historic materials and exercise extreme care when washing decorative features and damaged or loosened elements.

Silt and mud will accumulate not only on the floor and furnishings, but in interior wall cavities as well. Be sure to open electrical outlets and mechanical chases and rinse these areas thoroughly. Check wiring and connections for damage and repair as required. Let areas dry before closing them. Check heating and air conditioning ducts and clean out any mud or dirt before turning on the units. Large systems may need to be dismantled or cleaned by a professional.

To clean any remaining dirt and stains, use a standard non-sudsing household cleaning product as directed by the manufacturer. Special care should be used when working on or around historic materials. After cleaning, use a disinfectant to kill the germs, bacteria, and odor left by floodwaters.

Keep in mind that floodwaters and the remaining silt are contaminated by sewage and chemicals. Protect your eyes, mouth, and hands, and wear a mask and rubber gloves when cleaning out debris left by floodwaters. Use disinfectants to wash your hands before eating.

Before you begin to clean up your historic property, it is important to carefully document any damage to the structure. This is essential not only for insurance purposes, but also to record important historic building features. If building components are removed for cleaning or repair purposes, a photograph will help to ensure that they are reinstalled correctly.

Take photographs and make written notes describing the damage. A video recording is also a very effective way to document flood damage. Take photos or videos of any discarded items. Because of the intensive cleanup that takes place following a flood, materials might be carted away before an insurance adjuster is able to assess the loss.

Create an inventory of found items, dislodged architectural features, decorative fragments, and furnishings. **Do not throw away materials at will.** Furnishings and architectural elements can be carried a great distance by floodwaters, and items found on your property may be extremely valuable to a nearby restoration project.

## Hydrostatic Pressure

If your basement is flooded, it is likely that the level of water in your basement is the same as the groundwater level outside of your house. When this happens, pumping the water from the basement will do no good. New water will continue to seep in until the groundwater level drops.

### Foundation Collapse

You should be aware that pumping water from your basement can be dangerous. This water may be providing the necessary pressure to balance the hydrostatic pressure of the groundwater. If the groundwater level is higher than your basement floor and you pump the water from your basement, the foundation walls could be pushed inward and collapse.

If your basement is flooded with several feet of water and you are reasonably certain that your floor drains are operational, you can assume that the groundwater table is high. It is advisable to leave the water in place until the groundwater table sinks and the water recedes by itself. If your basement contains only a few inches of water, however, you may be able to pump it out safely. Keep in mind that if the groundwater level is higher than the floor, the water will return.

Even if you cannot pump the water out of the basement, you should still begin to ventilate the rest of the building. The sooner these materials dry, the less chance of water-related problems. Consult with local health officials to determine if there is any sanitizing agent that can be used to treat standing water in the basement.

Water can exert tremendous pressure on foundation walls and floor slabs. If any portion of a building lies below the groundwater level,

## As the Floodwaters Recede—A Checklist of Things To Do

The following checklist will help you respond to flood damage in historic and older buildings. Read the steps through carefully and take time to plan. While it is tempting to wade right in with a shovel and mop, it is very important to develop a plan for cleanup and rehabilitation. Unfortunately, overly zealous cleanup efforts can result in historic materials being carted away, excessively rough cleaning methods, and the unnecessary loss of historic fabric. The best way to prevent additional damage to historic structures and materials during a time of duress is to use caution and plan ahead.

- Follow all emergency rules, laws, and regulations
- Turn off all utilities
- Document building damage
- Wear protective clothing
- Stabilize any unstable structures with temporary bracing
- Use caution when pumping basement water
- Keep building properly ventilated
- Clean everything that got wet with a disinfectant
- Allow saturated materials to dry using natural ventilation
- Check for foundation damage
- Replace soil around foundation
- Save historic materials if possible
- Use caution when removing lead-based paint or any products containing asbestos
- Clean and repair roof and roof drainage systems to protect building from future damage

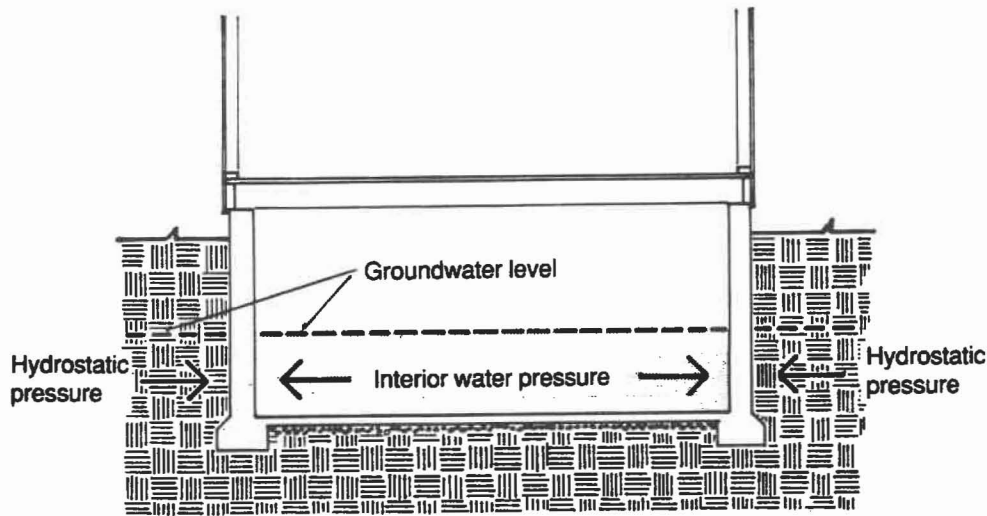

Water in basement can help to offset high groundwater pressure.

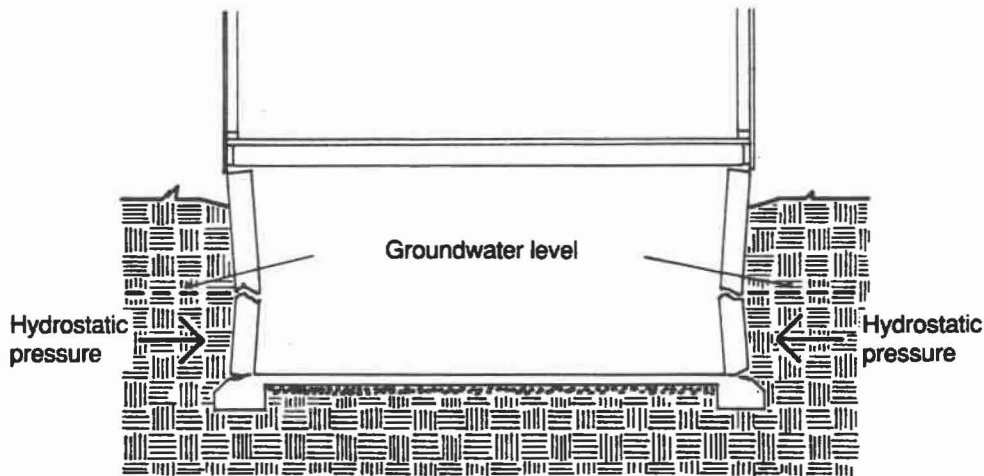

If water is pumped from basement when groundwater pressure is high, foundation walls may collapse.

**Figure 1.**  
**Hydrostatic Pressure**

one of two things will happen: basement slab heaving or loss of mortar.

### Basement Slab Heaving

If foundation walls are tight enough to hold back groundwater, it is likely to seep through the floor slab, causing it to leak or heave. In some instances, very high water pressure may be enough to raise the floor slab. Fortunately, this is not a common occurrence in historic buildings.

If your basement slab heaves, you cannot correct the problem immediately. First wait until the soil beneath the building dries thoroughly, as part of the problem may be the presence of clay soils that expand when wet. Concrete slabs in newer buildings are usually poured over a sand bed, which helps them to resist soil pressures, while older concrete floors were often poured right over the existing dirt. If you pour a

new slab before the clay dries, the new slab or surface could crack when the clay shrinks to its normal dimensions.

If the slab is still heaved or cracks remain after the water recedes and the soil has dried, there is little you can do except to repair the cracks or, in the case of severe heaving, pour a new slab.

## Loss of Mortar

The basement may leak and fill with water. This is usually the case with older buildings and actually protects the foundation walls from collapse if the groundwater level is too high. Unfortunately, as water passes through stone and brick foundation walls, it sometimes carries mortar with it.

The foundations of most older and historic buildings are masonry. Stone foundation walls with soft lime mortar are very durable, although the lime mortar does not hold up well to water erosion. Inspect the mortar of stone masonry foundation walls to ensure that it has not leached from the joints and made the wall unstable. If a significant amount of mortar has been lost, it can usually be replaced without dismantling the wall. In many cases, a "loose" mortar can be poured into the joints to fill the voids.

Make sure that replacement mortar is not too hard for the surrounding stone. If the wall is constructed of

sandstone, the new mortar should contain at least two parts hydrated lime to each part of white Portland cement and nine parts sand (known as ASTM "Type O" mortar). If the foundation wall is constructed of limestone or other relatively hard stone, a standard tuckpointing mortar may be used (ASTM "Type N" containing one part hydrated lime to one part white Portland cement and six parts sand).

If the foundation walls are constructed of brick masonry or concrete block, there will likely be less leeching of mortar than if the walls were constructed of stone. Nevertheless, they should be inspected for missing mortar and repaired in the same manner as aboveground walls, unless there is reason to suspect a more serious structural problem created by the flooding (see "Foundation Erosion" below). Generally foundations constructed of concrete block used a harder mortar containing gray Portland cement.

## Erosion

### Foundation Erosion

Water currents and water traveling in underground "streams" can erode soil beneath foundation walls and footings. Although this situation is not common, when it does occur the building's foundation will be destabilized and repairs will be necessary. The best evidence of structural destabilization is the appearance of cracks in the foundation walls and in plaster or drywall above the foundations.

Keep in mind, however, that not all cracks that appear after a flood are indications of long-term instability. Some may result from temporary expansion of clay soil around the foundation. When the soil returns to its natural water content, the cracks should shrink or, at the very least, not expand. Other cracks may result from moisture-related expansion of wood beams and joists tied to the foundation walls. These cracks should shrink as the wood dries.

**Figure 2. Foundation Erosion**

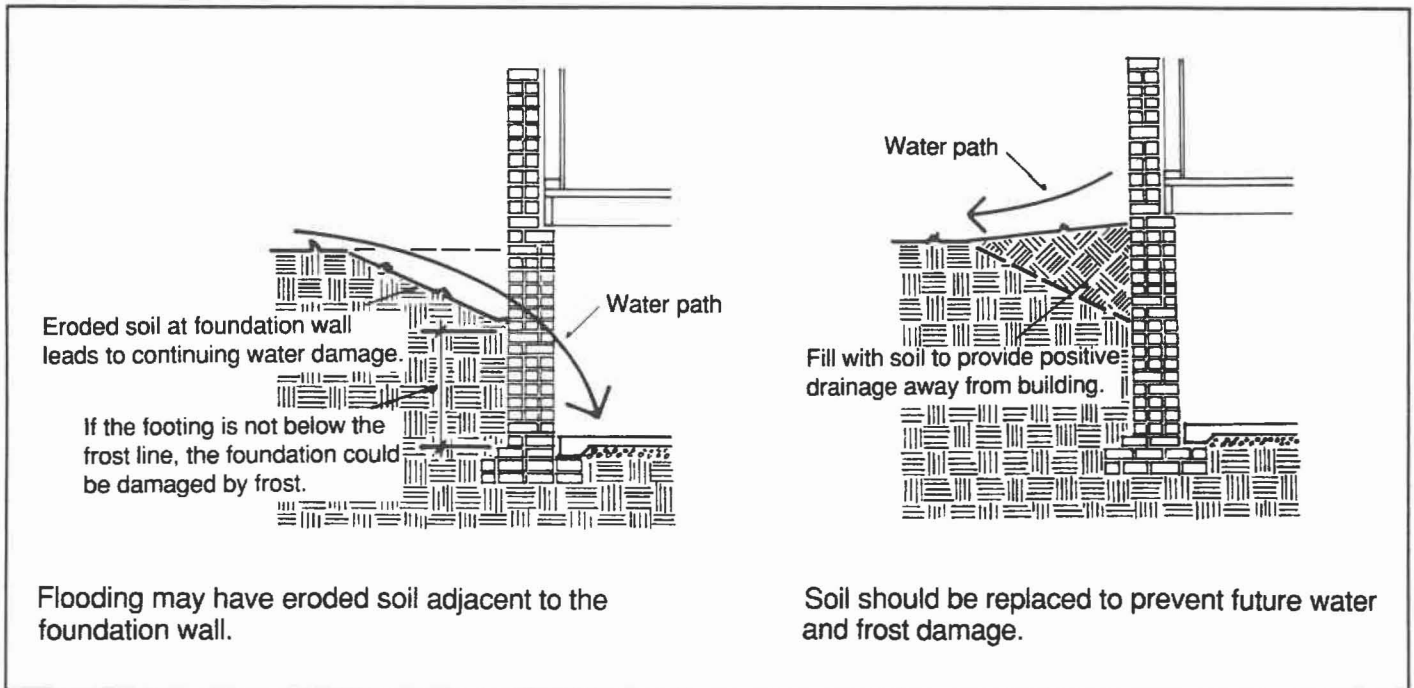

Cracks from foundation erosion, however, can be expected to worsen over time as the building settles slowly to its new soil support. The best indicator of this type of structural problem is cracks that move. Movement, particularly widening of cracks, is a sign of structural instability warranting careful examination by a qualified structural engineer or architect.

The best way to determine whether a crack is moving is to purchase a device called a "tell-tale." This small gauge is glued to a wall on either side of a crack. Its markings indicate the crack's horizontal and vertical movement over time. This device can be obtained from engineering or scientific supply firms or by writing the manufacturer directly. (Avongard Crack Monitor, 2836 Osage, Waukegan, IL 60087 (708) 244-4179.)

Another way to determine whether movement exists is to glue a glass microscope slide across a crack. If the slide breaks, movement is occurring.

### Soil Erosion

Water may erode the soil adjacent to your building. This can lead to two problems:

- The soil may be "dished" next to the building which may result in additional damage from future rain. The soil adjacent to the building should slope away from it to ensure that future rains do not drain into the building. After the floodwaters subside, check the soil drainage pattern and re-grade as necessary.
- A less common soil problem is the loss of enough dirt to protect

your foundation from frost-heaving during cold weather. If the foundation is not sufficiently below the frost line, it may heave upward when the ground beneath it freezes. For this reason, it is best to replace any lost dirt adjacent to the foundation.

### Heaving of Sidewalks and Slabs

Erosion can also affect paving. From a building conservation perspective, the worst problem occurs when eroded slabs of asphalt or concrete channel water into, rather than away from, buildings. As with soil erosion, this can lead to water problems from future rains.

If this condition exists, the slab should either be raised (by mud-jacking, for example) or it should be removed and replaced with one that drains properly.

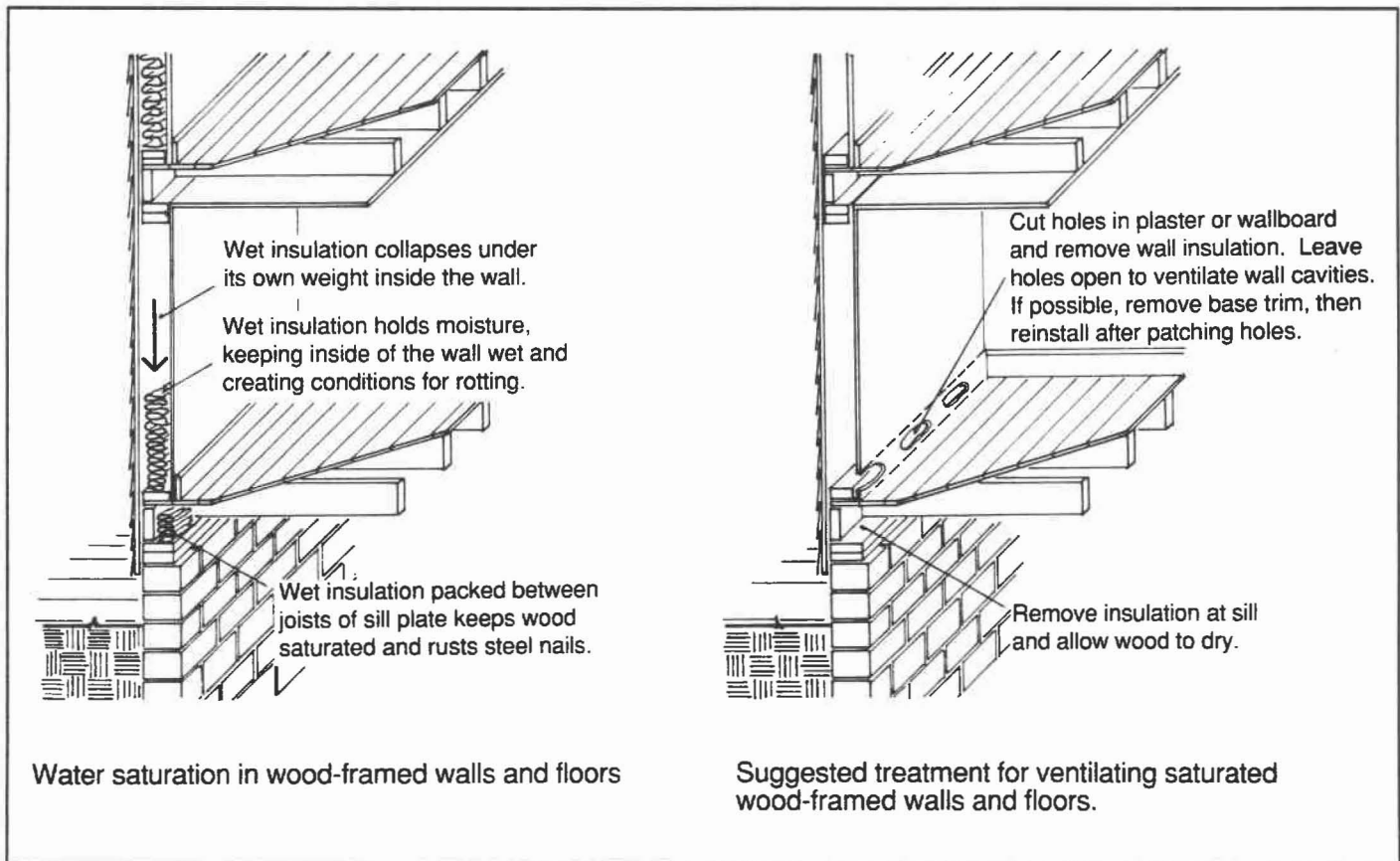

Figure 3. Treatment for saturated wood-framed walls and doors.

## Saturation of Insulation

With few exceptions, any insulation that has been immersed in water should be removed for two reasons:

- After being saturated, most insulation is rendered permanently ineffective, particularly loose-fill varieties, such as cellulose, vermiculite, rock wool, and blown fiberglass, which tend to collapse under their own weight.
- Saturated insulation holds water which, if left in place, can perpetuate high moisture conditions destructive to wood, masonry, and steel.

Some types of insulation may be left in place after water contact, such as closed-cell styrene and urethane board insulations that do not absorb water. These should be inspected to determine whether they hold moisture against wood or masonry materials or steel fasteners. If so, the insulation should be removed until all materials are dry. Any mud or silt that remains in the cavity should be removed regardless of the insulation's condition.

Other types of insulation, such as fiberglass battens, must be evaluated on a case-by-case basis. Glass fibers, in themselves, are not water absorbent, but if they impede the flow of air in a wall cavity, and thus the drying-out process, it may be necessary to remove them.

## Wood Rot

Wood rot occurs when natural fungi—present in virtually all construction lumber—grow in wood. Like other living organisms, they need food (wood), air, proper temperatures (between about 60-80 degrees F.), and water in order to grow. In most wood construction, the missing element is water which is why ordinary wood lasts for centuries when protected from moisture.

Fortunately for flooded buildings, the fungi must exist over a relatively long period of time in order for wood rot to be destructive. Damage from a one-time event, such as a flood, is usually negligible if the wood is allowed to air dry. Problems occur when saturated wood is encapsulated so that the water cannot evaporate.

Two areas where wood is normally encapsulated are wall cavities and sill plates, particularly when these areas are filled with insulation. Figure 3 describes treatment of walls and sill plates. To properly ventilate walls, it will probably be necessary to cut or drill holes—taking care not to damage pipes and wires buried in the walls—and remove the insulation.

## Masonry and Concrete Deterioration

### Soluble Salt Damage

Masonry and concrete contain impurities, including water-soluble salts. When these materials are saturated, the soluble salts dissolve and are carried to the surface during evaporation. The result is an unsightly white residue called efflorescence on the exterior or interior of the building—wherever water evaporates. These deposits are not usually harmful and frequently they dissolve and disappear naturally when it rains. Stubborn efflorescence may be removed with water, detergent and bristle brushes, or with chemicals.

Soluble salts can cause significant damage when the building's exterior surface has been treated with building sealer. If this is the case, the salts will travel toward the outside surface, but become trapped behind the surface by the sealer. The water vapor eventually evaporates, but the salts are left behind to crystallize and expand, pushing off the surface of the brick or stone in a process called spalling.

The presence of paint on masonry or concrete walls may also retard the passage of water. Because the paint does not penetrate the masonry or concrete, it is usually removed by the water passing through the wall or by the salt crystallization that takes place just under the paint layer. While the paint may be removed, the surfaces of the brick, stone, or concrete remain intact.

The most obvious way to prevent salt damage is to never apply sealer to a building. If your building has been sealed, there is little that can be done to prevent spalling.

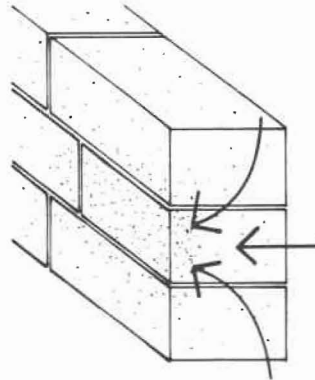

### Soluble Salts

Water trapped in masonry walls dissolves soluble salts. As water migrates to the surface, it carries the salts and deposits them on the face of the brick or stone. These deposits, called "efflorescence," are usually harmless and can be easily removed.

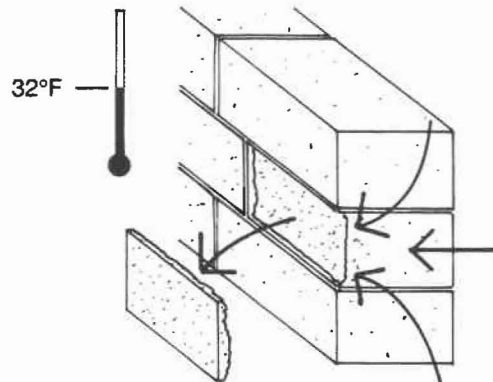

### Freeze Spalling

Freeze spalling occurs when liquid water remains in the wall when the outside air temperature reaches freezing. Water turns to ice crystals and expands and spalls the face of brick or stone.

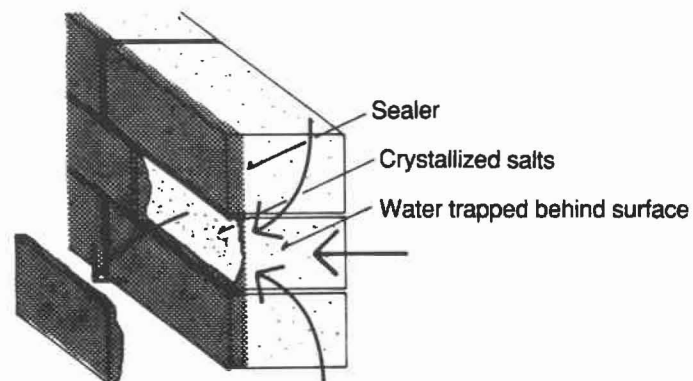

The outside surfaces of buildings are sometimes sealed to prevent water from soaking into the materials. Unfortunately, sealer also prevents liquid water from migrating outward. Water is trapped behind the surface and, as it evaporates, allows soluble salts to re-crystallize. When this happens, the salt crystals expand and spall the face of the brick or stone. Sealer also retards the migration of liquid water and increases the chance that flood-soaked masonry will be damaged by freeze spalling.

**Figure 4. Masonry and concrete deterioration**



## Freezing and Thawing Damage

When water freezes, it expands. If the water is encapsulated inside building materials, the expansion can tear them apart. Thus, if significant amounts of water remain in masonry or concrete by early winter, when the weather goes through rapid periods of freezing and thawing, the result is similar to the crystallization of salts: the faces of the masonry or concrete may spall.

Ordinarily, water will evaporate even from saturated masonry and concrete at a rapid enough rate that freeze-thaw damage will not occur. Some conditions under which evaporation may be impeded and spalling may take place are described below.

- Masonry or concrete has been treated with a building sealer. Although newer building sealers allow the passage of water vapor, they inhibit the flow of liquid water and can slow the rate of evaporation. Unfortunately, little can be done to mitigate the effects of building sealer. Some spalling may occur.
- Masonry or concrete has been painted. The vapor pressure of the water may cause some of the paint to fall off, helping to speed evaporation. Otherwise, short of paint removal, little can be done and some spalling may occur.
- Masonry or concrete has been covered with another building material, such as board insulation, wood siding or plasterboard. If the covering was installed flush against the masonry or concrete, it should be removed temporarily to allow the wall to dry out. If the material was installed over sleepers or spacers and an air space exists, it may not be necessary to completely remove the covering material, but it would be helpful to provide air holes to ventilate the wall.

## Damage to Metals

### Metal Fasteners

Most metal fasteners are made of iron or steel which rust and expand when exposed to water. Fasteners, such as nails, should not be harmed by immersion in floodwaters, as long as they are allowed to dry soon after the waters subside. Opening wall cavities and removing insulation may be necessary. If nails are subjected to long-term moisture, rust may become severe and the nails may fail.

Rusted or weakened nails probably will not cause significant structural problems in the lower portion of a building—the portion most likely to be immersed by floodwaters. In most cases, such as at the sill plate, the nails hold the wood in position but are not solely responsible for its support.

The exception to this is often porch floor joists. Porches are frequently fastened to the house only with nails which, if they fail, may cause the porch to collapse. If your porch was submerged, make sure it is well ventilated by removing solid porch skirts and allowing the air to flow freely.

Once the moisture is removed, iron nails pose cosmetic problems by causing rust stains on finished surfaces. This problem can be corrected by driving the nails further into the wood, caulking them, and applying a primer paint with topcoat.

### Damage to Exposed Metals

Most metals will not be permanently damaged by immersion in water. Durable metals such as aluminum, bronze, copper, and brass should survive the flooding completely intact. Commercial storefronts with cast-iron columns and stoops may experience

some rusting, but the surfaces can be sanded clean and repainted.

Stamped iron-based metal, most commonly found in “tin” ceilings and stamped metal cornices on commercial storefronts, poses more of a problem. Stamped metal consists of rust-prone iron, coated with lead and tin (called “terne”) or zinc (called “galvanized”) to prevent rust. These coatings are usually effective, unless water enters the insides of the stampings and is allowed to sit. The standing water penetrates the protective coating and the iron rusts. Stamped metal cornices that have been immersed should be inspected to make sure they haven’t filled with water. If so, find a way to drain the water and ventilate the back side, either by carefully prying a portion away from the building or by drilling small weep holes on the bottom. The holes can later be filled with auto body filler and repainted.

There is no easy remedy for stamped ceilings that have been immersed except to dry the building’s interior

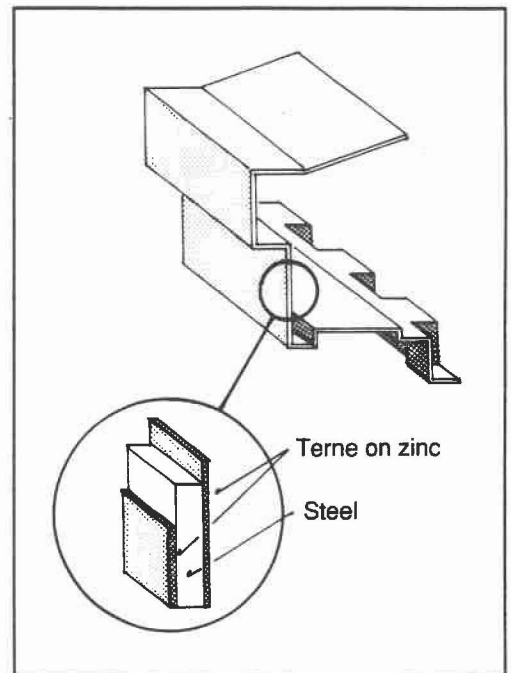

**Figure 5. Typical coated steel used in stamp metal**

and to monitor the ceilings for possible rusting. Drilling holes to drain water may be ineffective and removing sections of the ceiling would likely result in damage to the ceiling panels.

When repairs are necessary, stamped metal should be treated like auto body work. If surface rusting occurs on stamped metal, the rust should be removed by carefully scraping only the rusted areas, priming with a rust inhibitive paint, and then painting. Do not sandblast or attempt to chemically clean stamped metal or the protective coating will be removed and the metal will rust quickly.

### Damage to Imbedded Metals

The problems of exposed and imbedded iron are fundamentally different. When exposed iron corrodes, the problem is mostly cosmetic. When imbedded iron corrodes, it can damage surrounding materials.

When iron rusts, it expands and this expansion generates tremendous force. Of particular concern in flooded buildings are metal lintels—the flat pieces of steel used to support masonry or concrete above

door and window openings. Metal lintels are usually used on brick buildings and, when they rust, they can lift whole sections of a wall.

If your building has metal lintels and they were immersed in water, some rusting is likely to occur, although the rust expansion caused by the flooding alone will not cause a great deal of immediate damage. Of greater concern is damage to the surrounding materials that may allow water to enter on an ongoing basis and cause more severe rusting in the future.

After the water recedes and the building materials dry, check the mortar joints near the lintels to see that the mortar has not cracked or fallen out. If it has, repoint the area immediately to make sure that water cannot enter to create further rusting. Before repointing, scrape the metal to remove any loose rust scale. It is uncertain whether rust inhibitive primers are effective in retarding rust in these situations.

If other iron-based metals are imbedded in masonry or concrete, inspect them periodically and repair cracks in the surrounding materials if they occur.

## Damage to Interior Finishes

### Drywall

Drywall that was submerged will probably have to be replaced. Drywall consists of a relatively soft gypsum material held in place by a paper “sandwich.” The paper does not hold up well to water saturation and, in most cases, wet drywall will simply dissolve. If it was not wet severely, drywall may be salvageable after it dries. Even so, FEMA recommends replacement as contaminants may make it a permanent health hazard. As with other aspects of flood cleanup, use your judgment about whether to retain or discard affected drywall.

Plaster, on the other hand, is unpredictable when wet. Sometimes it survives with no damage, other times it must be replaced. Its durability depends on the plaster mix, the skill used in application, the degree of saturation, whether it is applied to walls or ceilings, and the type of lath used. Plaster over metal lath is more likely to require replacement than plaster over wood lath.

Check for obvious areas where plaster must be removed, such as ceilings with large sags. If your ceiling sags in an area more than about three feet in diameter, it may be difficult to repair the damage. That portion of the ceiling may need to be removed—with care. Falling plaster, especially wet falling plaster, can be dangerous. If the water level was above the ceiling and you suspect that it may contain standing water, you may want to poke drain holes—with a nail attached to the end of a long stick—in the plaster before attempting to remove it. Do not stand directly under the area being prodded in case the plaster loosens and falls.

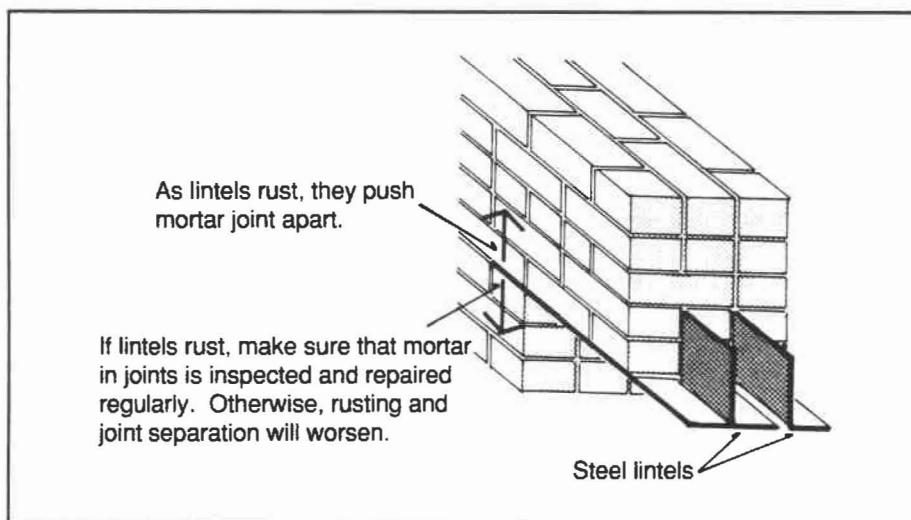

**Figure 6.** *The effect of floodwater on metal lintels in a brick masonry wall.*

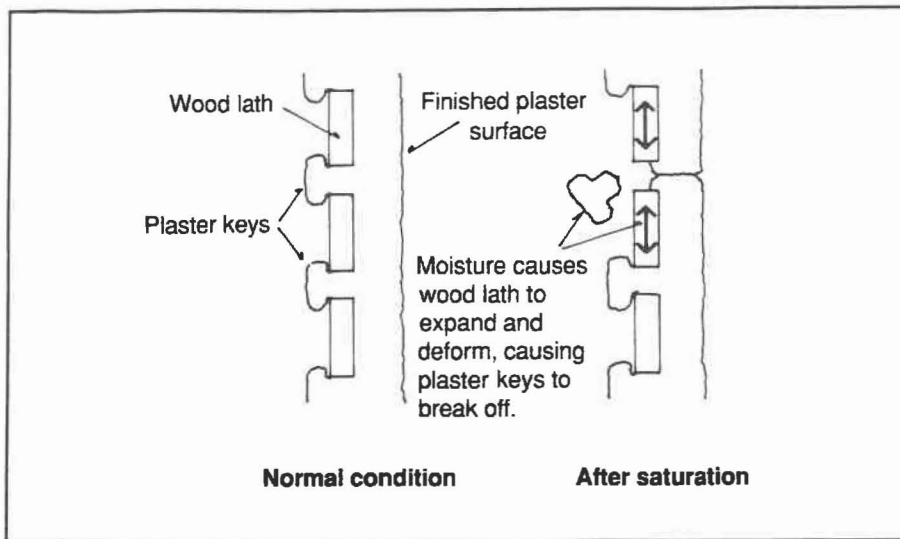

**Figure 7. Possible effect of saturation on plaster walls.**

Except for areas of obvious damage, the best way to determine whether plaster must be replaced is to let it dry and then inspect it. Here are some suggestions about how to determine whether plaster should be replaced:

- The surface condition of plaster may not tell you whether it is sound. If the plaster keys (sections of plaster that serve to anchor the plaster to the lath) have fallen off or if the lath has come loose from the building structure, the plaster may need to be replaced.
- You can sometimes tell if plaster is sound by tapping lightly on the wall with a piece of wood. Unsound plaster will sound hollow.
- If you ventilate wall cavities by opening holes, look for broken plaster keys. There will always be a few broken keys, but if the number is excessive, the plaster is likely in poor condition.
- Plaster damage can be repaired by re-anchoring the plaster to the wall studs and ceiling joists with screws and plaster washers. Sound plaster, especially decorative plaster, should be retained in place if it is salvageable.

### Damage to Wood Floors and Trim

It is difficult to determine whether wood trim that has been submerged needs to be replaced. Most wood will expand and deform when wet and then return more or less to its original form as it dries. The behavior of an individual piece of wood depends on its species, grain pattern, method of anchoring, and whether its grain structure was damaged when the wood expanded against other materials.

Tongue and groove hardwood floors are unlikely to return to their original condition. When they expand, their grain structures are usually damaged. If you have a saturated hardwood floor, let it dry thoroughly. Then, if it remains cupped, you can decide whether to sand the floor flat or replace it. When possible, retain original hardwood floors.

Non-interlocking board floors, such as plain pine boards, stand a good chance of returning to their original shapes when dried. A light, surface sanding and some re-nailing may be necessary.

Wood trim around baseboards, ceilings, doors, and windows is likely to survive a flood because it can

usually expand without crushing its fibers. After drying, it should return to its original form and should be retained.

Wooden doors in older and historic buildings are likely to be panel doors that add to the character of the building. Replacement with standard, hollow-core, flush doors may not be appropriate and the original doors should be retained when possible. Fortunately, panel doors usually survive flooding surprisingly well. If you have panel doors, let them dry in place. It may help to open them to allow better air circulation. As they dry, warping should disappear, and their fit and the condition of their glue joints should be inspected before determining whether they need further repair. Be sure that the doors are completely dry before attempting to repair or plane them. Also, if the original glue was not waterproof, the joints may have to be re-glued.

If you need to replace any doors, consider replicating original panel doors. Hollow core doors will likely need to be replaced because their internal spacers are usually made of cardboard which dissolves in water.

### Damage to Interior Paint

After the flood, most painted interior surfaces that were under water will have to be repainted due to water damage or contamination. Do not paint interior surfaces until they are completely dry and the interior humidity has returned to nearly normal levels. The exception is that wall surfaces can be painted with flat latex paint even if some dampness exists.

The paint on some surfaces, such as window trim, may have been damaged and soft enough to scrape off. If so, new paint will not adhere until the existing paint is removed and the wood is dry. Because the wood trim may contain lead-based paint,

especially in older buildings, observe caution when removing it and dispose of it properly.

### Wallpaper

In many cases, older and historic wallpaper may be saved after a flood, but the decision to retain or remove it is a difficult one. On the one hand, FEMA cautions that wallpaper paste may be a breeding ground for molds and contamination and that wallpaper significantly wet by floodwaters may have to be removed and replaced, even if it appears to be in good condition. On the other hand, if the wallpaper is of historical importance or original to your house, you may decide to retain it. The decision will be based on the degree of water damage, the cost of replacement or reproduction, and climate controls that may limit future growth of mold and bacteria.

If your house is historic and the extent of damage determines that the wallpaper must be removed, carefully remove several square feet, all the way down to the plaster. If possible, take samples from several different locations including the ceiling. Label which room the paper came from and store temporarily in a dry part of the house until the paper can be permanently preserved.

### Floor Coverings

Most older and historic homes retain few of their original floor coverings and most floor coverings can be discarded with no effect on a building's historic character.

One exception to this rule is tile floors which may be original. Even though tile is a durable material, the materials beneath it, such as wooden sub-floors and grout beds, may have been damaged. The only way to determine whether a tile floor is sound is to inspect it when

all of the building materials are dry. This might take a long time as the tile impedes the evaporation process.

If a preliminary inspection shows that the underlying structure may be damaged, the tile floor can be removed and re-laid when the materials have dried. Or the decision whether to remove or reinstall can be postponed until the materials have thoroughly dried with the tile floor in place. The latter method takes longer, but minimizes damage to the tiles.

The most common residential floor covering is wall-to-wall carpeting. Because of the risk of contamination, carpeting touched by the floodwaters should be discarded, unless it is small enough to be laundered, such as an area rug, or valuable enough to be professionally cleaned, such as an Oriental rug.

Floor tiles, such as vinyl flooring, and sheet flooring are probably not historic and should be removed to aid the evaporation process if the underlying wooden floor was submerged. On rare occasions, some sheet flooring, such as linoleum, may be historically significant. If this is the case and you wish to retain it, let the floor dry as best it can. Once dry, if the floor is level and the flooring adheres, you may leave it in place. If the bond between the floor and the covering fails, you may be able to remove and relay the flooring. There is no guarantee that either of these techniques will succeed. If it is impossible to relay the floor, make sure to save samples of the historic flooring.

## Exterior Paint Problems

Paint failure is likely to occur on any painted surface wet directly by floodwater or on surfaces through which excessive amounts of water will evaporate. Paint failure resulting from the passage of water or water vapor will show up as large sections of paint peeling all the way down to the underlying building material. If this happens, allow the underlying materials to dry thoroughly before attempting to repaint. If you paint before all the building materials have dried thoroughly, the water vapor pressure will "bubble" the new paint and it too will peel.

If the building materials are very wet, it may be necessary to postpone painting for a long time. You may wish to use a water-repellent wood preservative to help to protect the wood from water-related damage and the effects of sunlight until you can safely paint it.

## Summary

Churches, schoolhouses, stores, banks, homes, courthouses, and barns in river and coastal communities often bear watermarks on the walls where owners pencil in the dates and levels of significant floods—the 1937 Flood, the 1973 Flood, the Johnstown Flood. Yet many of these buildings have stood the test of time and survived devastating floods. While floodwaters can cause significant damage to historic buildings, they do not spell the end. With proper cleaning and drying out procedures, the only reminder of floodwaters in historic structures should be a watermark and date on the wall.

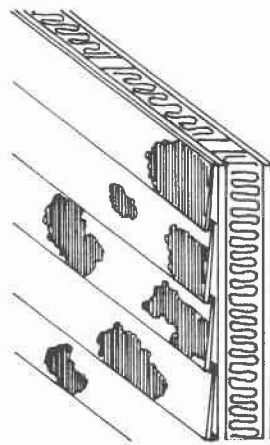

Illustrated here are the effects of saturated insulation in a wood-framed wall. Liquid water and water vapor passing outward through the wood push the paint off the building, all the way down to the bare siding. A similar type of paint failure will occur if flood soaked walls are painted before they have dried completely.

**Figure 8. Moisture-related paint failure**

## Acknowledgements

This *Information* booklet is adapted from the State Historical Society of Wisconsin's *Treatment of Flood-Damaged and Older Historic Buildings*, prepared by Jim Sewell, senior preservation architect. Richard Wagner of David H. Gleason Associates drafted the illustrations based on Mr. Sewell's original drawings.

## Resources

The **National Trust for Historic Preservation** and the **state historic preservation offices** are offering emergency grants for flood-damaged historic properties through special funding from the National Park Service.

Grants from the National Trust are available to nonprofit incorporated organizations, educational institutions, governmental agencies and individuals for a variety of preservation activities. Assistance will not be provided for construction projects and, due to the federal nature of these funds, cannot be used for such purposes as lobbying, fund raising, aid to religious institutions, entertainment or to match any other federal grant.

Grant projects must specifically relate to damages incurred in connection with the flood, but may not be used to reimburse expenses prior to the date the county in which the site is located was declared a disaster area, unless specifically approved by the grant award. No matching funds are required.

Contact the National Trust's Midwest Regional Office in Chicago or the Mountains/Plains Regional Office in Denver for more information. The addresses for these offices are found on the back cover along with a list of the states under the jurisdiction of each office.

The Preservation Briefs series, published by the **National Park Service**, provide useful technical information in dealing with the effects of floodwater damage to your old or historic building. Contact your state historic preservation office or write: Superintendent of Documents, Government Printing Office, Washington, D.C. 20402-9325. Among the titles available are:

- #1 *The Cleaning and Waterproof Coating of Masonry Buildings*
- #2 *Repointing Mortar Joints in Historic Brick Buildings*
- #6 *Dangers of Abrasive Cleaning to Historic Buildings*
- #7 *The Preservation of Historic Glazed Architectural Terra-Cotta*
- #8 *Aluminum and Vinyl Siding on Historic Buildings*
- #9 *The Repair of Historic Wooden Windows*
- #10 *Exterior Paint Problems on Historic Woodwork*
- #11 *Rehabilitating Historic Storefronts*
- #15 *Preservation of Historic Concrete: Problems and General Approaches*
- #16 *The Use of Substitute Materials on Historic Building Exteriors*
- #18 *Rehabilitating Interiors in Historic Buildings*
- #20 *The Preservation of Historic Barns*
- #21 *Repairing Historic Flat Plaster Walls and Ceilings*
- #22 *The Preservation and Repair of Historic Stucco*
- #23 *Preserving Historic Ornamental Plaster*
- #27 *The Maintenance and Repair of Architectural Cast Iron*
- #28 *Painting Historic Interiors*

**The Federal Emergency Management Agency (FEMA)** also produces several publications that may be helpful to you. These are:  
*Repairing Your Flooded Home - FEMA 234, Flood Emergency and Residential Repair Handbook - FIA 13, Floodproofing Residential Structures - FEMA 102, Design Manual for Retrofitting Flood-Prone Residential Structures - FEMA 114.*

Copies of these publications may be available through your state or local office of emergency services. Otherwise, you may order them through FEMA's Chicago regional office by calling (312) 408-5500, or by writing to: FEMA Publications Office, P.O. Box 70274, Washington, D.C. 20024.

The location of FEMA Regional Offices and the states served are listed below. If your state is not listed, contact: National Office, State and Local Programs and Support Directorate, Office of Disaster Assistance Programs, Washington, D.C. 20472 or call (202) 646-3615.

**FEMA - Region V**  
175 West Jackson Blvd. 4th floor  
Chicago, IL 60604-2698  
(312) 408-5500  
(Illinois, Indiana, Michigan, Minnesota, Ohio, Wisconsin)

**FEMA - Region VII**  
911 Walnut Street, Room 200  
Kansas City, MO 64106  
(816) 283-7061  
(Iowa, Kansas, Missouri, Nebraska)

**FEMA - Region VII**  
Denver Federal Center,  
Building 710  
Box 25267  
Denver, CO 80225-0267  
(303) 235-4811  
(Colorado, Montana, North Dakota, South Dakota, Utah, Wyoming)

## If You Need Help

Assistance of various types is available from your **state historic preservation office**. Assistance includes survey and assessment of damage of historic resources. In addition the SHPO administers the historic rehabilitation tax credit program for owners of income producing properties certified by the SHPO as historic rehabilitation projects. These tax credits may help to offset the costs of carrying out flood damage repair. Other specific flood-related assistance available from nine different states is summarized below. If your state is not listed, contact the National Conference of State Historic Preservation Officers (NCSHPO), Suite 332, 444 North Capitol Street, Washington, D.C. 20001-1512 or call (202) 624-5465.

### **Illinois Historic Preservation Agency**

1 Old State Capitol Plaza  
Springfield, IL 62701  
(217) 785-4512  
FAX (217) 524-7525

### **State Historical Society of Iowa**

Capitol Complex  
East 6th and Locust Street  
Des Moines, IA 50319  
(515) 281-8719  
(800) 528-5270  
FAX (515) 282-0502

### **State Assistance Programs Available in Iowa**

- **Resource Enhancement and Protection Program (REAP)** - All remaining funds for this state grant program are being reallocated to emergency needs. Both historic preservation and broader cultural preservation can be addressed. Requires local match.
- **Cultural Resource Emergency Attack Team** - Coordinates the provision of technical and financial assistance for the recovery of cultural resources from the effects of natural disasters anywhere in the state.

### **Kansas State Historical Society**

120 West Tenth  
Topeka, KS 66612  
(913) 296-4788  
FAX (913) 296-6622

### **Minnesota Historical Society**

345 Kellogg Boulevard West  
St. Paul, MN 55102-1906  
(612) 296-5434  
FAX (612) 282-2374

### **Missouri Department of Natural Resources**

Historic Preservation Program  
205 Jefferson  
P. O. Box 176  
Jefferson City, MO 65102  
(314) 751-7858  
FAX (314) 751-8656

### **Nebraska State Historical Society**

P.O. Box 82554  
Lincoln, NE 68501  
(402) 471-4769  
FAX (402) 471-3100

### **State Historical Society of North Dakota**

Heritage Center  
612 E. Boulevard Avenue  
Bismarck, ND 58505  
(701) 224-2667  
FAX (701) 224-3000

### **South Dakota State Historical Society**

State Historical Preservation Center  
P.O. Box 417  
Vermillion, SD 57069  
(605) 677-5314  
FAX (605) 677-5364

### **State Assistance Programs Available in South Dakota**

- **State Tax Benefits** - Property tax benefits are available to owners of properties listed on the State Register of Historic Places. Owners can receive an eight year moratorium on property tax assessment for improvements on historic buildings.

**State Historical Society of Wisconsin**

Division of Historic Preservation  
816 State Street  
Madison, WI 53706  
(608) 264-6500  
FAX (608) 264-6404

State Assistance Programs  
Available in Wisconsin

- Architectural assistance from the Division of Historic Preservation.

**The National Endowment for the Humanities** has created an emergency fund of \$1 million for libraries, museums and other cultural institutions ravaged by floods throughout the Midwest. Affected institutions can apply immediately for emergency grants of up to \$30,000 to support steps necessary to preserve books, records, manuscripts, art, and cultural artifacts. This opportunity will extend through July 31, 1994. Applications should be addressed to Chairman's Office, National Endowment for the Humanities, 1100 Pennsylvania Avenue, N.W., Washington, D.C. 20506. For more information, contact the NEH Division of Preservation and Access at (202) 606-8570.

**The National Endowment for the Arts' Museum Program** is concerned primarily with works of art and with institutions that care for and exhibit works of art. Funds from several categories within the Museum Program, as well as the Challenge and Advancement programs, can be applied toward disaster planning. For more information contact: National Endowment for the Arts, Museum Program, 1100 Pennsylvania Avenue, N.W., Washington, D.C. 20506 (202) 682-5442.

**The American Institute for the Conservation of Historic and Artistic Works (AIC)** and the **National Institute for Conservation of Cultural Property (NIC)** have put together a package of useful materials relating to the conservation of flood-damaged archival materials, textiles, art work, antiques, ceramics, etc. To obtain a free package write: National Institute for Conservation of Cultural Property, 3299 K Street, N.W., Suite 403, Washington, D.C. 20007.

**The Small Business Administration (SBA)** can provide both direct and bank participation disaster loans to qualified homeowners and businesses to repair or replace damaged or destroyed private property when the SBA administrator declares a "disaster loan area" under SBA's statutory authority. The disaster assistance numbers for SBA are: Iowa, Missouri, Kansas and Nebraska (800) 473-0477; Illinois, Wisconsin, and Minnesota (800) 359-2227; South Dakota and North Dakota (800) 488-5323.

**Regional and state museum associations** can help coordinate assistance by other museums and museum professionals. For more information contact: Midwest Museums Conference, P.O. Box 11940, St. Louis, Mo. 63112. (314) 454-3110 or Mountains-Plains Museum Association, Box 335, Manitou Springs, Colo. 80829 (719) 593-8840.

The mission of the National Trust for Historic Preservation is to foster an appreciation of the diverse character and meaning of our American cultural heritage and to preserve and revitalize the livability of our communities by leading the nation in saving America's historic environments.

Support for the National Trust and for this booklet is provided in part by grants from the U.S. Department of the Interior, National Park Service. The opinions expressed in this publication are not necessarily those of the U.S. Department of the Interior or the National Trust. Nor does the mention of trade names or commercial products constitute endorsement or recommendation by the Department of the Interior or the National Trust.

This program receives federal financial assistance. Under Title VI of the Civil Rights Act of 1964, Section 504 of the Rehabilitation Act of 1973, and the Age Discrimination Act of 1975, the U.S. Department of the Interior and the National Trust prohibit discrimination on the basis of race, color, national origin, handicap or age in their programs.

## JOIN THE HISTORIC PRESERVATION NETWORK

The Preservation Forum of the National Trust is a membership program for professionals and organizations. The benefits and privileges of membership include subscriptions to *Historic Preservation Forum*, *Historic Preservation* magazine, *Historic Preservation News*, participation in financial/insurance assistance programs, technical advice, and substantial discounts on professional conferences and educational publications. New *Information* booklets are available free upon request. To join, send \$75 annual dues to: Preservation Forum, National Trust for Historic Preservation, 1785 Massachusetts Avenue, N.W., Washington, D.C. 20036 (202) 673-4296.

The National Main Street Network is a membership program for individuals and organizations involved in downtown and neighborhood commercial district revitalization. Network members receive the same benefits as Preservation Forum members and, in addition, receive a subscription to *Main Street News*, access to the Network Exchange telephone assistance line and discounts on Main Street Network publications, conferences and workshops. To join, send \$195 annual dues to the National Main Street Network at the address listed above or call (202) 673-4219.

---

### Offices of the National Trust for Historic Preservation

#### National Headquarters

1785 Massachusetts Avenue, N.W.  
Washington, D.C. 20036  
(202) 673-4296

#### Mid-Atlantic Office

Cliveden, 6401 Germantown Ave.  
Philadelphia, Pa. 19144  
(215) 438-2886  
(*Delaware, District of Columbia, Maryland,  
New Jersey, Pennsylvania, Puerto Rico, Virginia,  
Virgin Islands, West Virginia*)

#### Midwest Office

53 West Jackson Blvd., Suite 1135  
Chicago, Ill. 60604  
(312) 939-5547  
(*Illinois, Indiana, Iowa, Michigan, Minnesota,  
Missouri, Ohio, Wisconsin*)

#### Northeast Office

Seven Faneuil Hall Marketplace, 5th Floor  
Boston, Mass. 02109  
(617) 523-0885  
(*Connecticut, Maine, Massachusetts, New  
Hampshire, New York, Rhode Island, Vermont*)

#### Southern Office

William Aiken House  
456 King Street  
Charleston, S.C. 29403  
(803) 722-8552  
(*Alabama, Arkansas, Florida, Georgia, Kentucky,  
Louisiana, Mississippi, North Carolina, South  
Carolina, Tennessee*)

#### Mountains/Plains Office

910 16th Street, Suite 1100  
Denver, Colo. 80202  
(303) 623-1504  
(*Colorado, Kansas, Montana, Nebraska, North  
Dakota, Oklahoma, South Dakota, Wyoming*)

#### Texas/New Mexico Field Office

500 Main Street, Suite 606  
Fort Worth, Tex. 76102  
(817) 332-4398  
(*New Mexico, Texas*)

#### Western Office

One Sutter Street, Suite 707  
San Francisco, Calif. 94104  
(415) 956-0610  
(*Alaska, Arizona, California, Guam, Hawaii,  
Idaho, Micronesia, Nevada, Oregon, Utah, Wash-  
ington*)

Copyright © 1993

National Trust for Historic Preservation